

# Viewpro U30TIR

## 30x Zoom EO + IR Dual Sensor Object Tracking Camera Gimbal

### User manual

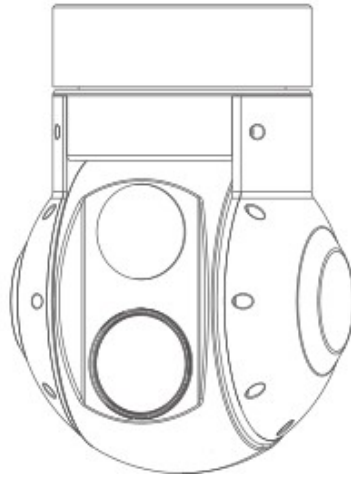

#### Contents

##### U30TIR Pinpoint-precision Gimbal

1. Gimbal introduction .....	2
2. Object tracking function .....	2
3. Gimbal description .....	3
4. Packing list .....	4
5. Gimbal dimension .....	4
6. Installing .....	5
7. Mechanics@Electronic characteristics .....	5
8. Working characteristics .....	5
9. Gimbal's signal wire box .....	6

##### SONY EV7520 30x Starlight Camera

1. SONY EV7520 30x starlight camera .....	10
---	----

##### 640 25mm Thermal Imager Parameter

1. 640 25mm Thermal imager Parameter.....	12
---	----

##### GPS Information Display and Serial Port Control Wiring Diagram

1. GPS and connection of control box .....	13
2. GPS baud rate .....	13
3. GPS introduction .....	13
4. TTL serial port control wiring instructions .....	13

#### Gimbal Introduction

U30TIR is a pinpoint-precision professional 3-axis gimbal which features high stability, small size, light weight and low power consumption. The 3-axis gimbal based on FOC motor control technology, adopts pinpoint-precision encoder in each motor.



The speed of U30TIR gimbal is adjustable, LOW speed mode is used for large zoom range, the control will be more accurate; Fast speed mode is used for small zooming range, which makes the gimbal control sensitive and quick. Also the one-key to center function will allow the gimbal return to initial position automatically and rapidly.

U30TIR supports PWM, S.BUS and serial command control, suitable for close range remote control or remote data command control.

### Object Tracking Function

#### 1. Function description

Build-in normalization, cross-correlation and tracking algorithm, combining with object missing recapture algorithm, achieve stable track of the target.

Support custom characters of user OSD, adaptive gate, cross cursor, tracking information display.

#### 2. Tracking Performance

- 1) Update rate of deviation pixel 50Hz
- 2) Output delay of deviation pixel <15ms
- 3) Minimum object contrast 5%
- 4) The minimal signal-to-noise ratio (SNR) 4
- 5) Minimum object size 16\*16 pixel
- 6) Maximum object size 160\*160 pixel
- 7) Tracking speed 32 pixel/frame
- 8) The mean square root values of pulse noise in the object position <0.5 pixel
- 9) Object memory time 100 frames

### Gimbal Description

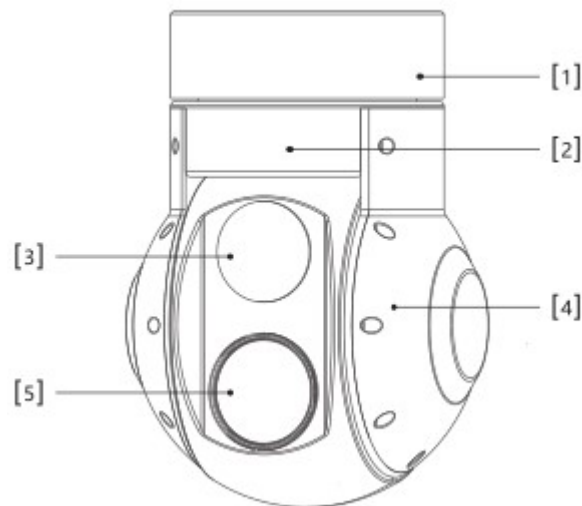

- [1] Damping box
- [2] YAW axis motor
- [3] Thermal infrared camera
- [4] Pitch axis motor
- [5] HD zoom camera

---

Please make sure that the motor is not stopped by any object during the rotation, if the gimbal is blocked during rotation, please remove the obstruction immediately.

---



**Packing list**

- Gimbal\*1
- Screw pack\*1(M3\*5mm button head hexagon screw\*16)
- Copper cylinders\*4      Damping balls\*12

**Gimbal Dimension**

unit:mm

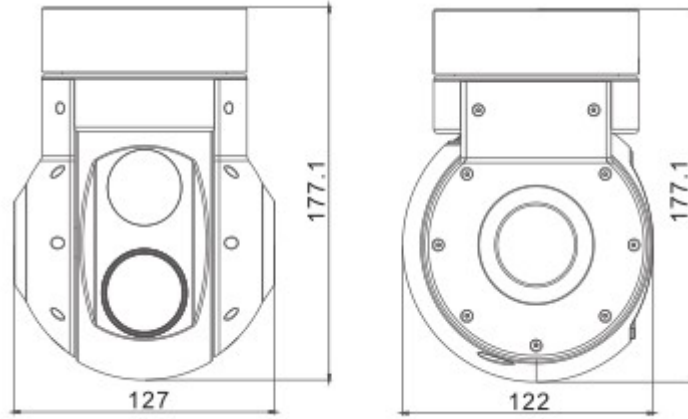

**Installing**

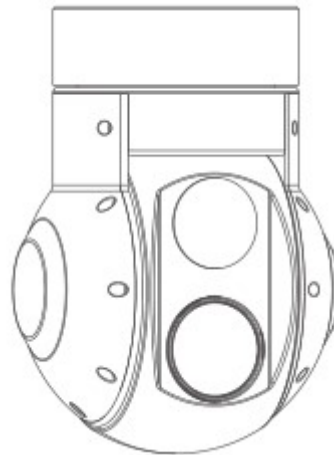

**Mechanics@Electronic Characteristics**

Input voltage	3S~4S	Idle current	400mA@16V
Dynamic current	500mA@16V	Working environment temp.	-20°C ~ +80°C
Weight	1150g	Size	L127*W 122*H177.1mm

**Working Characteristics**

Pitch/Tilt: Pitch angle range of action : $\pm 90^\circ$
Roll: Roll angle range of action : $\pm 85^\circ$
Yaw/Pan: Yaw angle range of action : $\pm 170^\circ$
Vibration angle: Pitch/Roll: $\pm 0.01^\circ$ , Yaw: $\pm 0.01^\circ$

**Connection of Control Box and Wiring Instruction**

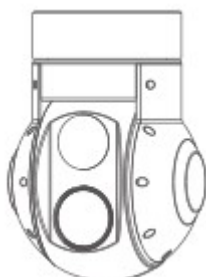

HDMI: micro HDMI OUTPUT  
1080P 60fps default

SD card: max 128G, class10  
 FAT32 or exFAT format

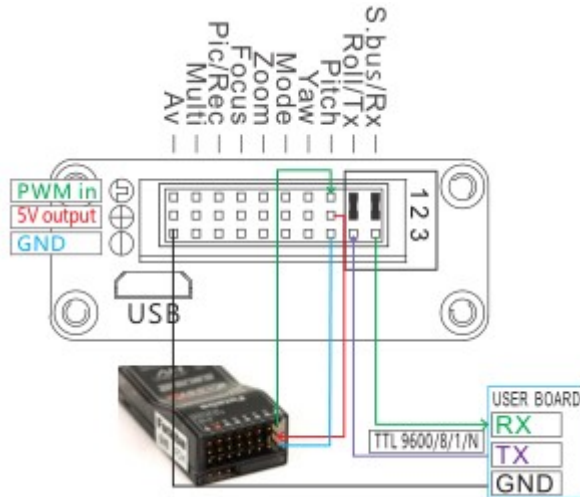

S.bus/Rx: Connect to Rx2 for track function.  
 Roll/ Tx: Connect to Tx2 for track function.  
 Pitch: PWM in, pitch control



1 Pitch up



2 Pitch stop



3 Pitch down

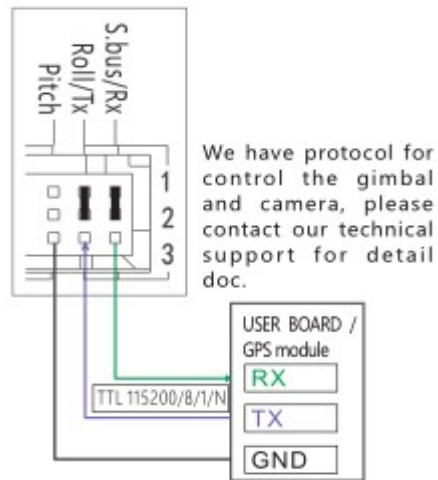

Yaw: PWM in, Yaw control



1 Yaw right



2 Yaw stop



3 Yaw left

Mode: Change the speed / home position

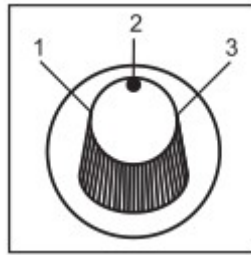

Position 1: Lowest speed for pitch and yaw.

Position 2: Middle speed for pitch and yaw.

Position 3: Highest speed for pitch and yaw. The speed is continuously quickly from 1 to 3.

One click: Home position.

Two click: Look down.

Three click: Yaw not followed by frame.

Four click: Yaw followed by frame.

Five click: Restore the factory settings.

(Click = from 2 to 3 and back to 2 quickly)

ZOOM: Zoom the camera



1 Zoom tele



2 Stop zoom



3 Zoom wide

Focus: Focus the camera



1 Switch 2 to 1: IR color, white hot, black hot, pseudo color.



2



3 Switch 2 to 3: picture in Picture. EO+IR, IR+EO, EO only, IR only.

Pic / Rec: Picture / start record, stop record



1 Switch 2 to 1: Start record / stop record. Start record, the OSD display rec hh:mm:ss ;



2 Stop record, the OSD display STBY.



3 Switch 2 to 3: Take a picture. OSD display 'REC IMG' a second.

#### Multi: Tracking control



1: Position 1 exit the tracking

Switch 1 to 2: Display the cross cursor. Adjust the object to the cross cursor.



2: Switch 2 to 3: Start tracking. Change the object during tracking.



Switch 3 to 2: Display the cross cursor, use Pitch / Yaw to adjust the cross cursor.

Switch 2 to 3: Start tracking.

AV: NO AV output this model.

#### SONY EV7520 30x Starlight Camera

		FCB-EV7520
<b>Imager Sensor</b>		1/2.8-type Exmor R CMOS
<b>Lens</b>		30x
<b>Picture Quality</b>		Full HD 1080 (1920*1080)
<b>Minimum Illumination</b>		Colour: 0.01 lx(F1.6, AGC on,1/30 s)
<b>Defog</b>		Yes
<b>Digital Zoom</b>		12x (360x with optical zoom)
<b>Imager Sensor</b>		1/2.8-type Exmor R CMOS
<b>Image Sensor (Number of effective pixels)</b>		Approx.2.13 Megapixels
<b>Signal System</b>		1080p/59.94,1080p/50,1080p/60, 1080p/30,1080p/29.97,1080p/25, 1080i/59.94,1080i/50,1080i/60, 1080i/30,720p/59.94,720p/50, 720p/60, 720p/30, 720p/29.97, 720p/25, N T S C * 1 , P A L * 1
<b>Minimum Illumination (50%)</b>	<b>High sensitivity mode</b>	Colour: 0.01 lx (F1.6,AGC on,1/30s)
	<b>Normal mode</b>	Colour: 0.1 lx (F1.6,AGC on,1/30s)
<b>S/N ratio</b>		more than 50dB
<b>Gain</b>		Auto / Manual 0dB to 50.0dB (0 to 28 steps + 2 steps / total 15 steps) Max.Gain Limit 10.7 dB to 50.0dB (6 to 28)



		steps + 2 step/ total 12 steps)
<b>White Balance</b>		Auto, ATW, Indoor, Outdoor, Outdoor Auto, Sodium Vapor Lamp (Fix /Auto /Outdoor Auto), One-push, Manual
<b>Shutter Speed</b>		1/1s to 1/10,000s, 22 steps
<b>Sync System</b>		Internal
<b>Exposure Control</b>		Auto, Manual, Priority mode(shutter priority & iris priority),Bright, EV compensation, Slow AE
<b>Backlight Compensation</b>		Yes
<b>Aperture Control</b>		16 steps
<b>Lens</b>		30x optical zoom f = 4.3 mm (wide) to 129.0 mm (tele) F1.6 to F4.7
<b>Digital Zoom</b>		12x (360x with optical zoom)
<b>Focusing System</b>		Auto (Sensitivity: normal, low),one-push AF, Manual, Interval AF,Zoom Trigger AF, Focus compensation in ICR on
<b>Horizontal Viewing Angle</b>	<b>1080p mode</b>	63.7° (wide end) to 2.3° (tele end)
	<b>720p mode</b>	63.7° (wide end) to 2.3° (tele end)
	<b>SD</b>	47.8° (wide end) to 1.7° (tele end)
<b>Minimum Object Distance</b>		10 mm (wide end) to 1200 mm (tele end) (Default: 300 mm)

#### 640 25mm Thermal Imager Parameter

Horizontal FOV		24.6°
Vertical FOV		18.5°
Diagonal FOV		30.4°
Detective Distance (Man: 1.8x0.5m)		735 meters
Recognize Distance (Man: 1.8x0.5m)		184 meters
Verified Distance (Man: 1.8x0.5m)		92 meters
Detective Distance (Car: 4.2x1.8m)		2255 meters
Recognize Distance (Car: 4.2x1.8m)		564 meters
Verified Distance (Car: 4.2x1.8m)		282 meters
Thermal Imager Spec	Working mode	Uncooled long wave (8μm~14μm) thermal imager
	Detector pixel	640*480
	Pixel size	17μm
	Focusing method	Athermal prime lens
	Emissivity correction	0.01~1
	NETD	≤50mK (@25°C)
	MRTD	≤650mK (@characteristic frequency)

	Image enhancement	Auto adjust image brightness and contrast ratio
	Color palette	Black, white, pseudo color
	Auto Non-uniform correction	Yes (no shutter)
	Digital zoom	2x, 4x
	Sync correct time	Yes
	Temperature type	Temperature bar (pseudo color display) max temp, min temp, FOV center temp
	Temperature warning	-20°C~120°C
Thermal Object Tracking	Update rate of deviation pixel	25Hz
	Output delay of deviation pixel	<3ms
	Minimum object size	16*16 pixel
	Maximum object size	128*128 pixel
	Tracking speed	±32 pixel/frame
	Object memory time	100 frames (4s)

### GPS Information Display and Serial Port Control Wiring Diagram

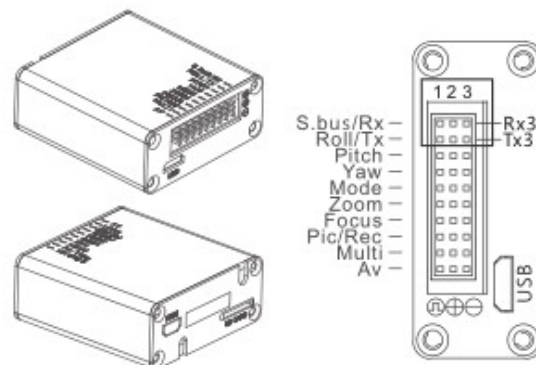

To use the serial port function, please use the jumper cap to connect RX1 and RX2, TX1 and TX2. External serial port TX connect with TX3. External serial port RX connect with RX3. External serial port GND connect with GND of wiring box.

**Note: The signals in the black square are all TTL serial ports. Do not connect 5V and GND to serial data Interface!**

The output of data radio stations (TTL 3.3 V) directly controls the gimbal and camera movements, in which the gimbal actions include:

- 1, Yaw control and angle output, pitch control and angle output, speed setting, angle setting, stop, return to Home;
- 2, camera actions include: zooming, focusing, start record, stop record, taking photos, record / photo Switch, zoom times information output, etc;
- 3, when there is no respond on the command from the control box, you need to enter the 4, serial port baud rate 115200, 8-bit data bit, 1 stop bit, no check bit, HEX.

For specific protocols, please contact us for technical support.